

Yusen Logistics Mexico

Jordan Dewart
Vice President



April 30, 2014



Agenda



- About Mexico – Facts, Age and Auto-boom
- Intermodal Shipping: Rail is becoming a Great option
- Incoterms
- Shipping to Mexico
 - Passport Service
 - Trans-border Service
 - Case Study
- Partnering with a Full Service 3PL / IMC



Mexico Facts



- President: Enrique Peña Nieto since 2012; to end in 2018.
- Population (2013): 119 million
- Unemployment (Apr 2014): 4.8%
- Debt to GDP ratio (Dec 2013): 42.8%
- 8th Automobile Manufacturer (2013) projected to be top 5 by 2016
- Expected to keep a +3.5% growth year over year in GDP

- Free trade agreements with more than 50 countries and regions:



Source: Mexican Ministry of Economy, 2012

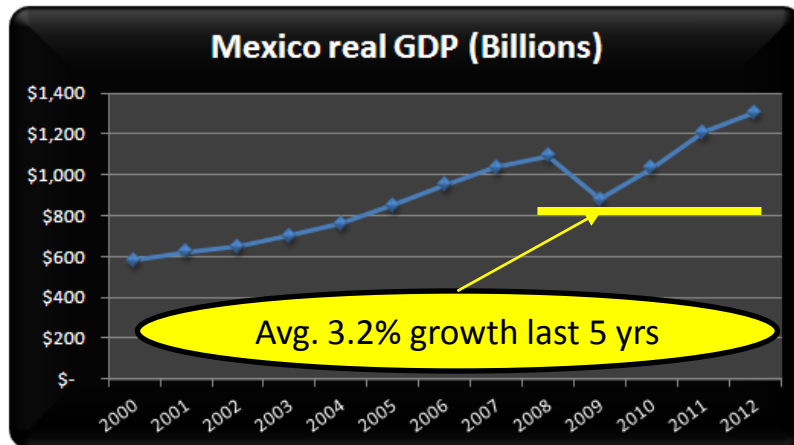

Source: The World Bank, 2013



Source: The World Bank, 2014

Mexico's Auto-boom

Light Vehicle Production





Intermodal Shipping



Rail Is Becoming A Great Option



- Rail service has improved significantly both on the US and Mexican Side.
- Cost effective solution
 - Generally longer haul makes economic sense.
 - New options to northwest corner of Mexico – West Coast markets
- Avoids “produce season” in South Texas.
- Despite these advantages, rail still greatly lags behind trucking, WHY?

Incoterms – a handy tool for shipping into Mexico

- Take advantage of Incoterms:
 - Transfer of risks and costs to buyer or seller
 - Unified obligations for contracting parties
 - International validity
- Intermodal use of Incoterms:

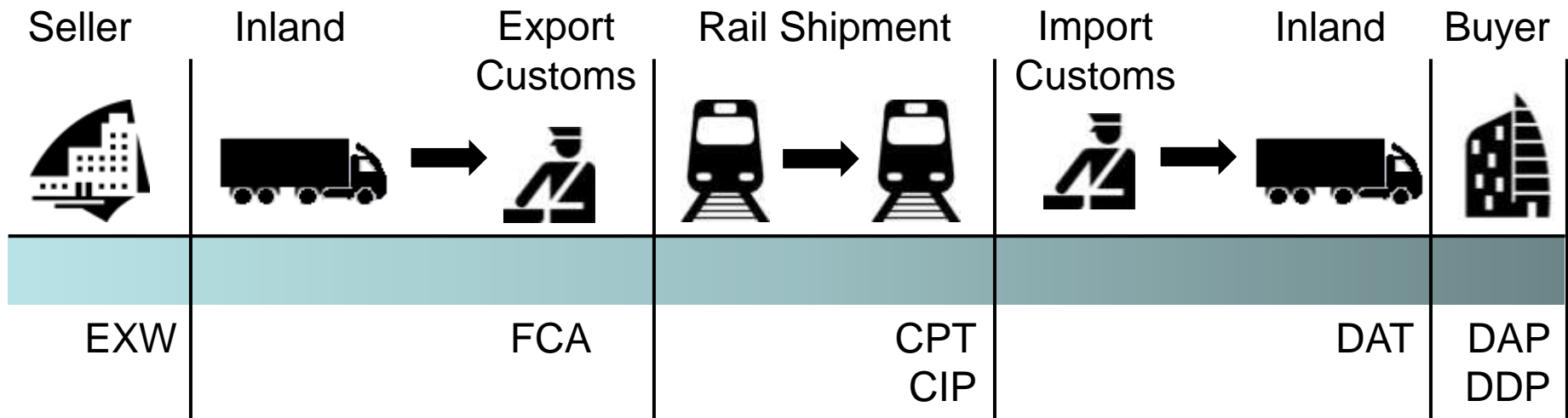
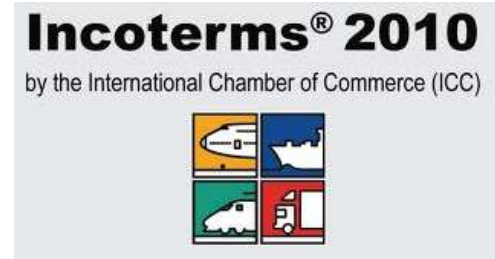

Shipping to Mexico – “Border Direct” Service

- Takes advantage of US side rail savings & Mexico OTR Transit.
- Same customs clearance process as trucking.
- Easy to setup with existing supply chain partners.
- Rates are very competitive as they can include fuel surcharge and border crossing fees.

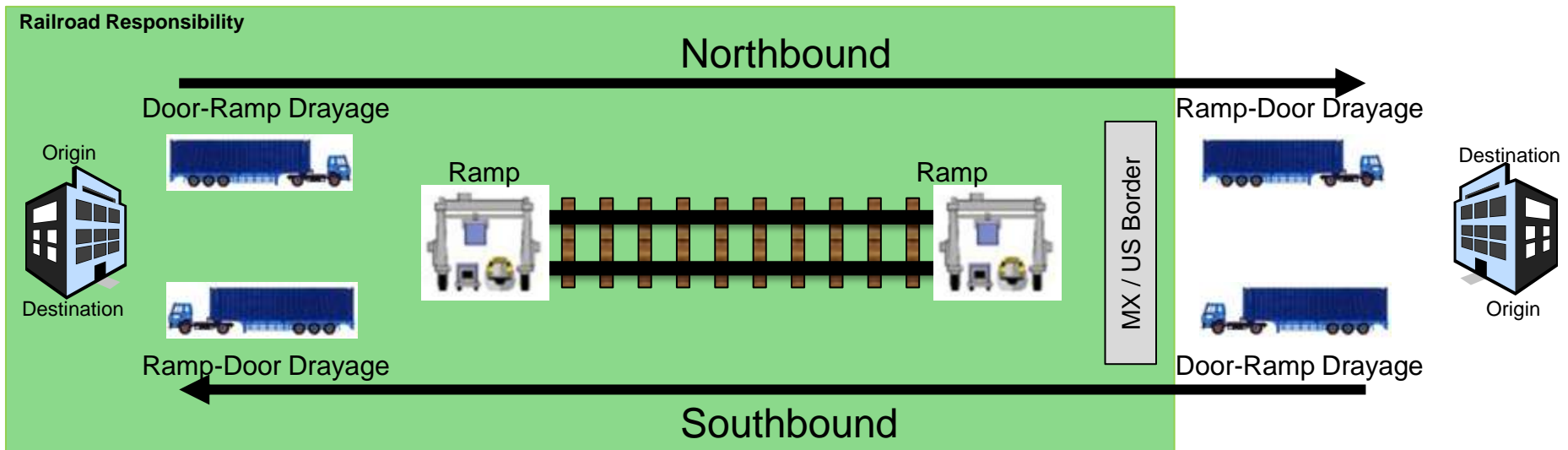

Shipping to Mexico – “Mexico Direct” Service

- Bypass the congested Laredo border crossing
- No delays at the border
- Smaller Customs fees / border dray charges eliminated
- Increased Security when entering and crossing into Mexico
- Some cargo liability maintained while in the railroad
- Greenest solution as total use of railroads

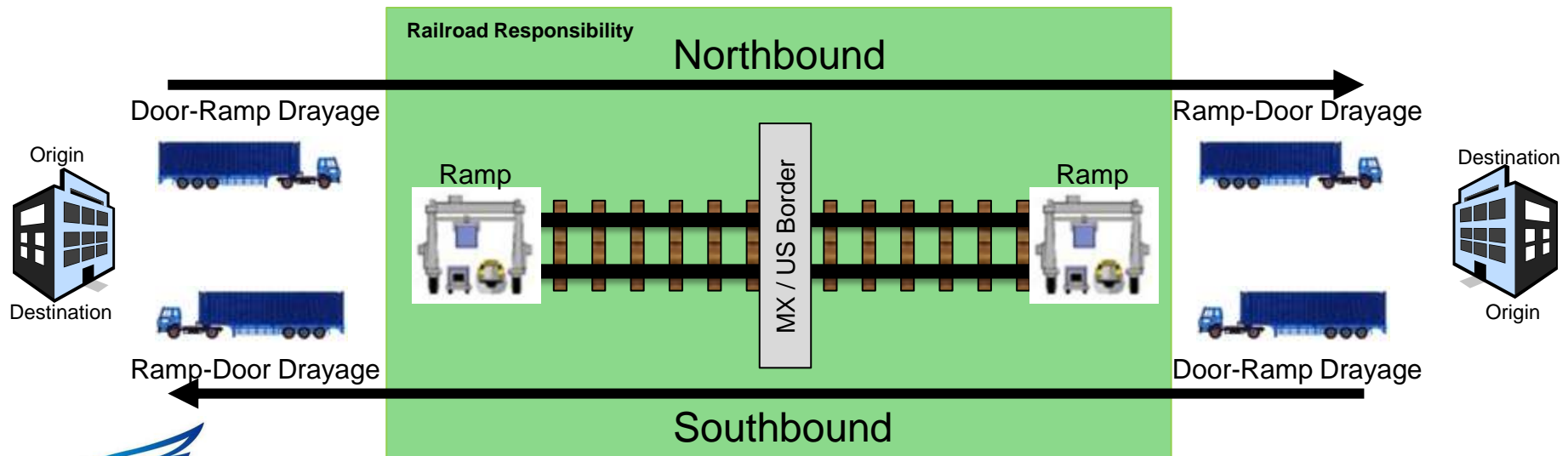

Case Analysis : Flatbed to Intermodal

- **Origin:**
 - Steel Manufacturing, Midwest
- **Destination:**
 - Central, Mexico
- **Commodity:**
 - Bundles of Steel Stacks
 - Each bundle weighs 10,000 lbs.
- **Service Type:**
 - Loads on an OTR platform
 - Switches to an Intermodal container in Detroit via crane transload.
 - Pulled to a terminal in Chicago and heads to Laredo, TX.
 - Forwarded OTR to deliver in Puebla

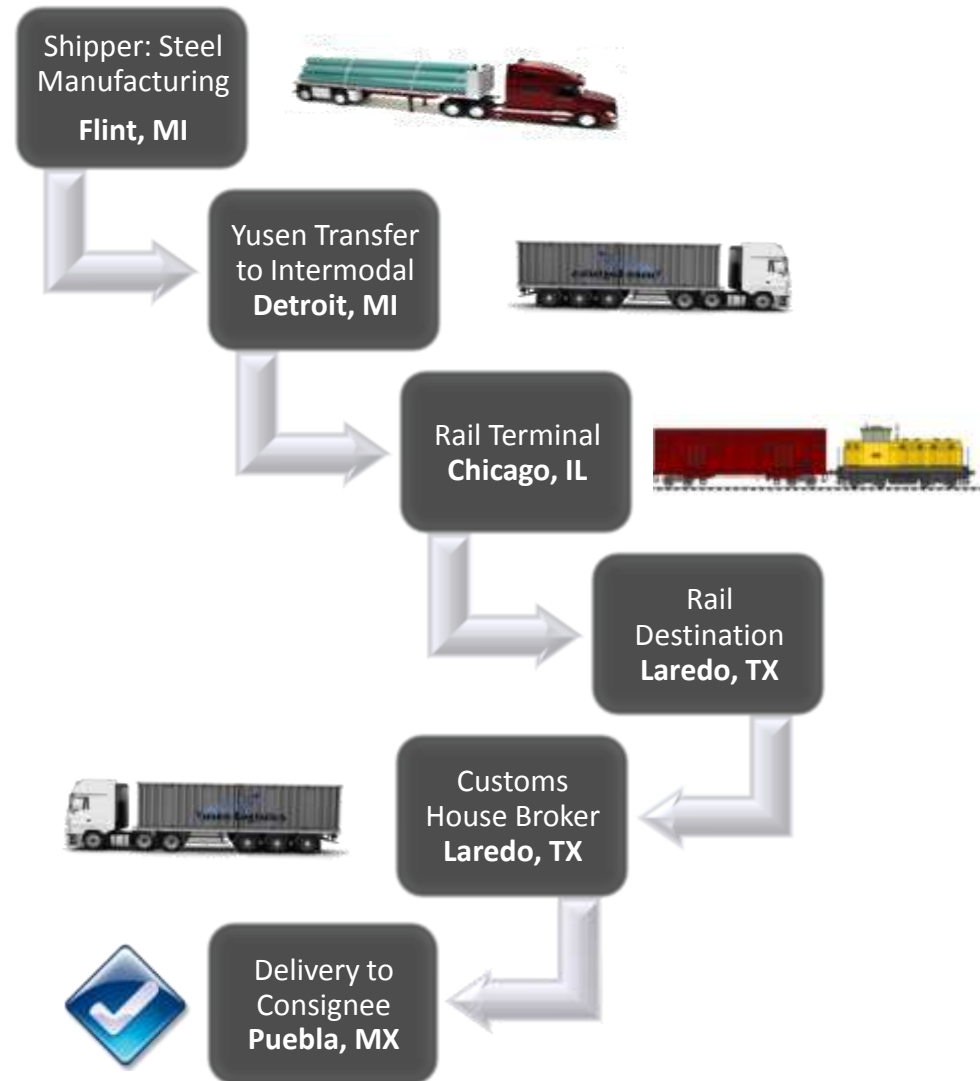

Advantages of partnering with a Full Service 3PL/ IMC

- Take advantage of overall cost savings, regardless of incoterm.
- Superior capacity – working with all rail companies.
- Innovative solutions to unique supply chain challenges.
- Physical presence throughout network (USA, Laredo, Mexico).
- Customer centric vs Asset centric.
- Competitive pricing through route optimization.
- Global network reaches beyond North America when needed.





Thank you!

